

AAXICO TECHNICAL SERVICES

PRODUCT RELEASE

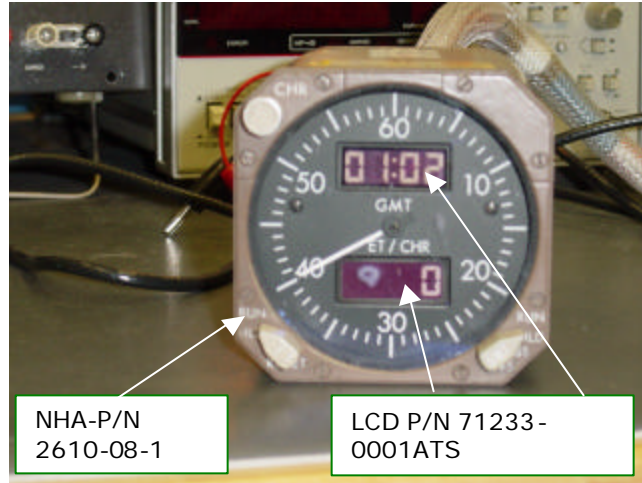

**AAXICO Technical Services (ATS) is pleased to announce PMA
on the following Part Number:**

OEM	End Item P/N	Description	OEM P/N	Approved Replacement PMA P/N	Eligibility
Smith Industries	2610-08-1	LCD	71233-0001	71233-0001ATS	B737-300 B737-400 B737-500 B757 Series B767-200/300

Advantages of Product Improvement: Identical to OEM. Price advantage over OEM product. Immediate availability of inventory through AAXICO.

Contact any AAXICO office listed below for pricing.



Corporate Headquarters * Miami, Florida * Tel: +1-305-592-4633 * Fax: +1-305-592-6828 * SITA: MIAXSXD
 European Office * Hampshire, England * Tel: +44 (0)1730 268641 * Fax: +44 (0)1730 268701 * SITA: LGWXSXD
 Southern Africa Office * Johannesburg * Tel: +27 11 9786440 * Fax: +27 11 9786374
 Asia-Pacific Office * Singapore * Tel: +65 64835003 * Fax: +65 64835002 * SITA: SINSXSD
 China Office * Beijing * Tel: +86-10-64382701 * Fax: +86-10-64382725
www.aaxico.com * sales@aaxico.com

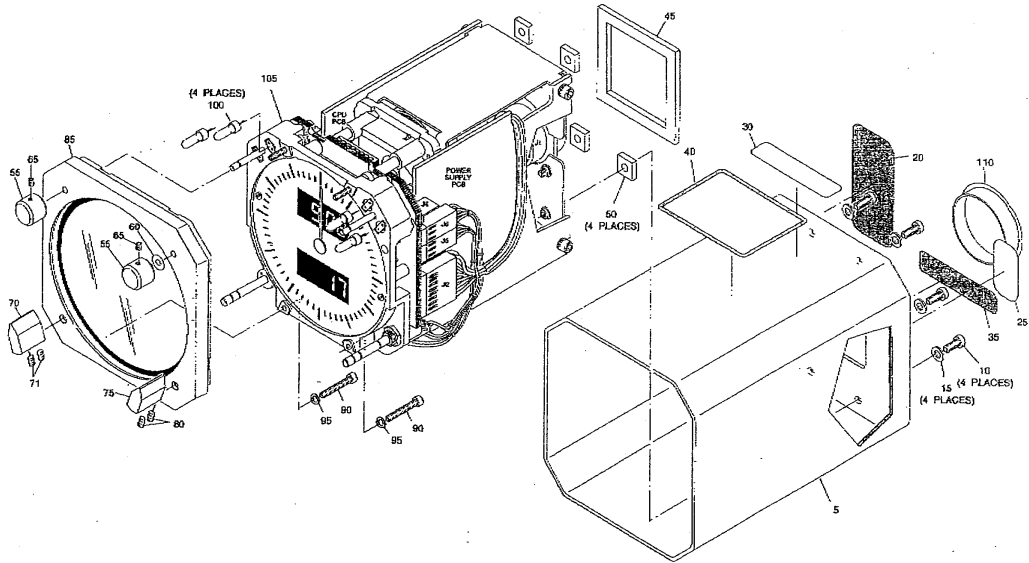

IPL FIGURE 1. MODEL 2610 ELECTRONIC CHRONOMETER, P/N 2610-08-1.

31-21-08
PAGE 1021/1022
MAR 24, 1997

SMITHS INDUSTRIES
Aerospace
COMPONENT MAINTENANCE MANUAL
MODEL 2610

FIG/ ITEM NO.	PART NUMBER	AIRLINE PART NUMBER	NOMENCLATURE						EFF CODE	UNITS PER ASSY
			1	2	3	4	5	6		
1-										
-1	2610-08-1		CHRONOMETER, DIGITAL ELECTRONIC (ESDS) P							RF
5	200831-002		• ASSEMBLY, HOUSING (NON REPAIRABLE ASSY) ATTACHING PARTS						P	1
10	MS51957-13		• SCREW, PHM, CROSS, #4-40 (V96906) 900060-001						P	4
15	MS15795-803		• WASHER, FLAT, #4 SS (V96906) 901002-002						P	4
			----- ***							
20	501481-002		• PLATE, IDENTIFICATION						P	1
25	500203-001		• LABEL, MODIFICATION (MOD A) (POST SB 2610-31-2)						P	1
30	501892-001		• LABEL, PMA						P	1
35	501277-001		• PLATE, SOFTWARE ID						P	1
40	501571-001		• LABEL, ESD						P	1
45	501143-001		• GASKET, CONNECTOR						P	1
50	501468-001		• GASKET, PAD						P	4
55	501151-002		• KNOB, INSTRUMENT (REPLD BY ITEM 55A)						P	2
-55A	501151-007		• KNOB, INSTRUMENT (REPLCS ITEM 55)						P	2
			ATTACHING PARTS							
60	902010-004		• SHIM, MYLAR						P	1

31-21-08

PAGE 1023
MAR 24, 1997

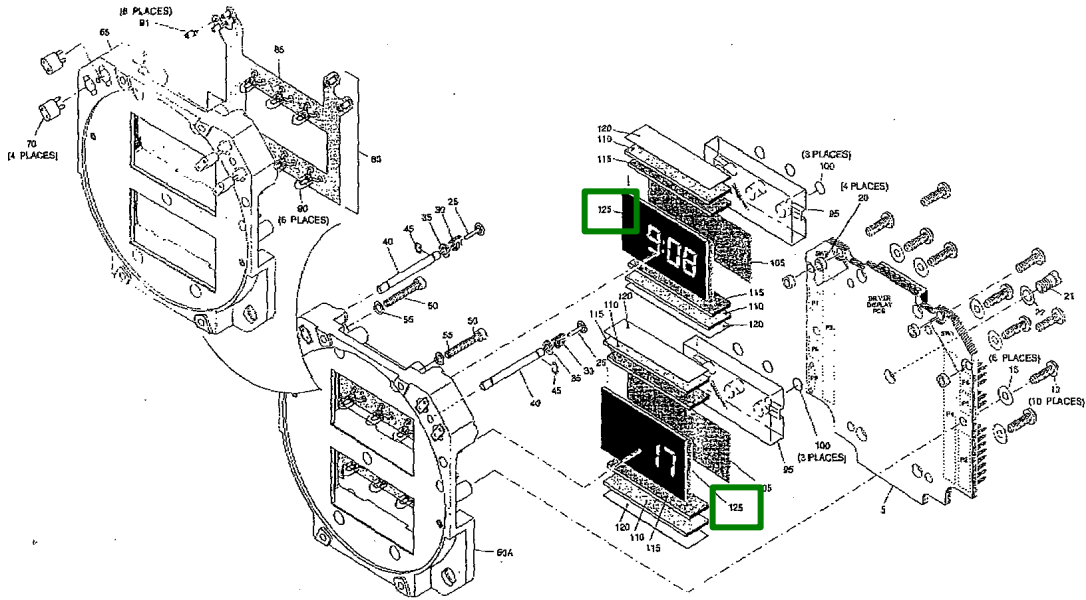

IPL FIGURE 8. DISPLAY ASSEMBLY, P/N 101067-01-01, -02-01.

31-21-08
PAGE 1055/1056
MAR 24, 1997

SMITHS INDUSTRIES
Aerospace
COMPONENT MAINTENANCE MANUAL
MODEL 2610

FIG./ITEM NO.	PART NUMBER	AIRLINE PART NUMBER	NOMENCLATURE						EFF CODE	UNITS PER ASSY	
			1	2	3	4	5	6			
8-											
80	100606-01-01							•• ASSEMBLY, FLEX LIGHTING (PRE SB 2610-31-20 MOD E) (REPLD BY ITEM 80A)	P	A	1
-80A	100606-02-01							•• ASSEMBLY, FLEX LIGHTING (POST SB 2610-31-20 MOD E) (REPLCS ITEM 80)	P	B	1
85	720336-001							••• BOARD, LIGHTING, FLEX WIRING	P		1
90	MS90451-7152							••• LAMP (V96906) 911101-003			6
91	0400015014727040							••• PIN, RECEPTACLE (V3N087) 726181-001 (POST SB 2610-31-20 MOD E)		B	8
95	200874-002							• BLOCK, LIGHT	P		2
100	501410-002							• FILTER, LIGHT	P		6
105	501444-004							• FILTER, GLASS (REPLD BY ITEM 105A)	P		2
-105A	501444-003							• FILTER, GLASS (REPLCS ITEM 105)	P		2
110	726051-023							• CONNECTOR, ELASTOMERIC	P		4
115	726051-022							• CONNECTOR, ELASTOMERIC	P		4
120	501529-004							• FILTER, POLYESTER	P		10
125	71233-0001							• LCD, DUAL CELL	P		2

P INDICATES PROPRIETARY ITEM
- INDICATES ITEM NOT ILLUSTRATED

PARTS MANUFACTURER APPROVAL NO. PQ1569CE
 PRODUCTION APPROVAL LISTING-SUPPLEMENT NO. #40
 DATE: March 8, 2004

FEDERAL AVIATION ADMINISTRATION-PARTS MANUFACTURER APPROVAL

AAXICO Technical Services
 8881 NW 13 Terrace
 Miami, Florida 33172
 (305) 592-4633

Part Name	Part Number	Approved Replacement For	FAA Approval Basis and Approved Design Data	Installation Eligibility: Make	Installation Eligibility: Model
Pin-Nozzle Lock	1301M32P1 0ATS	General Electric P/N 1301M32P10	Test and Computation Per 14 CFR Part 21, Section 21.303(c)(4) FAA Design Data Approval per FAA Letter dated 02/25/04, Dwg # 1301M32P10ATS, Rev: 3, Date: 12/01/03 or later FAA approved revision.	General Electric	CF6-80C2

Liquid Crystal Display	71233-0001ATS	Smith Industries P/N 71233-0001	Identity per 14 CFR Part 21, section 21.303(c)(4) FAA Design Data Approval per FAA 8110-3 dtd 2/18/04, Dwg # 71233-0001ATS, Rev "A" dtd 2/18/04 or later FAA approved revision.	Boeing	757 Series 767-200/300
------------------------	---------------	---------------------------------	---	--------	---------------------------

-----End of Listing-----

Note: Minor design changes (reference 14 CFR part 21.93 and 21.95) must be submitted in a manner as determined by the ACO. Major design changes (reference 14 CFR part 21.93 and 21.97) to drawings and specification are to be handled in the same manner as that for an original FAA-PMA.

Larry B. Orlando
 Manager, Orlando MIDO

PARTS MANUFACTURER APPROVAL NO. PQ1565CE
 PRODUCTION APPROVAL LISTING-SUPPLEMENT NO. #35
 DATE: December 8, 2003

FEDERAL AVIATION ADMINISTRATION-PARTS MANUFACTURER APPROVAL

AAXICO Technical Services
 8881 NW 13 Terrace
 Miami, Florida 33172
 (305) 592-4633

Part Name	Part Number	Approved Replacement For	FAA Approval Basis and Approved Design Data	Installation Eligibility: Make	Installation Eligibility: Model
Liquid Crystal Display	71233-0001ATS	Smith Industries P/N 71233-0001	Identity Per CFR Part 21, Section 21.303(c)(4), FAA design data approval per FAA 8110-3 dated 12/5/03 Dwg No. 71233-0001ATS, Rev: N/C, Date: 12/05/03 or later FAA approved revision.	Boeing	737-300 737-400 737-500

-----End of Listing-----

Note: Minor design changes (reference 14 CFR part 21.93 and 21.95) must be submitted in a manner as determined by the ACO. Major design changes (reference 14 CFR part 21.93 and 21.97) to drawings and specification are to be handled in the same manner as that for an original FAA-PMA.

Richard E. Popad
 P.E. Littleton
 Manager, Orlando MIDO
 Reissue: 12/10/03

